

"A"

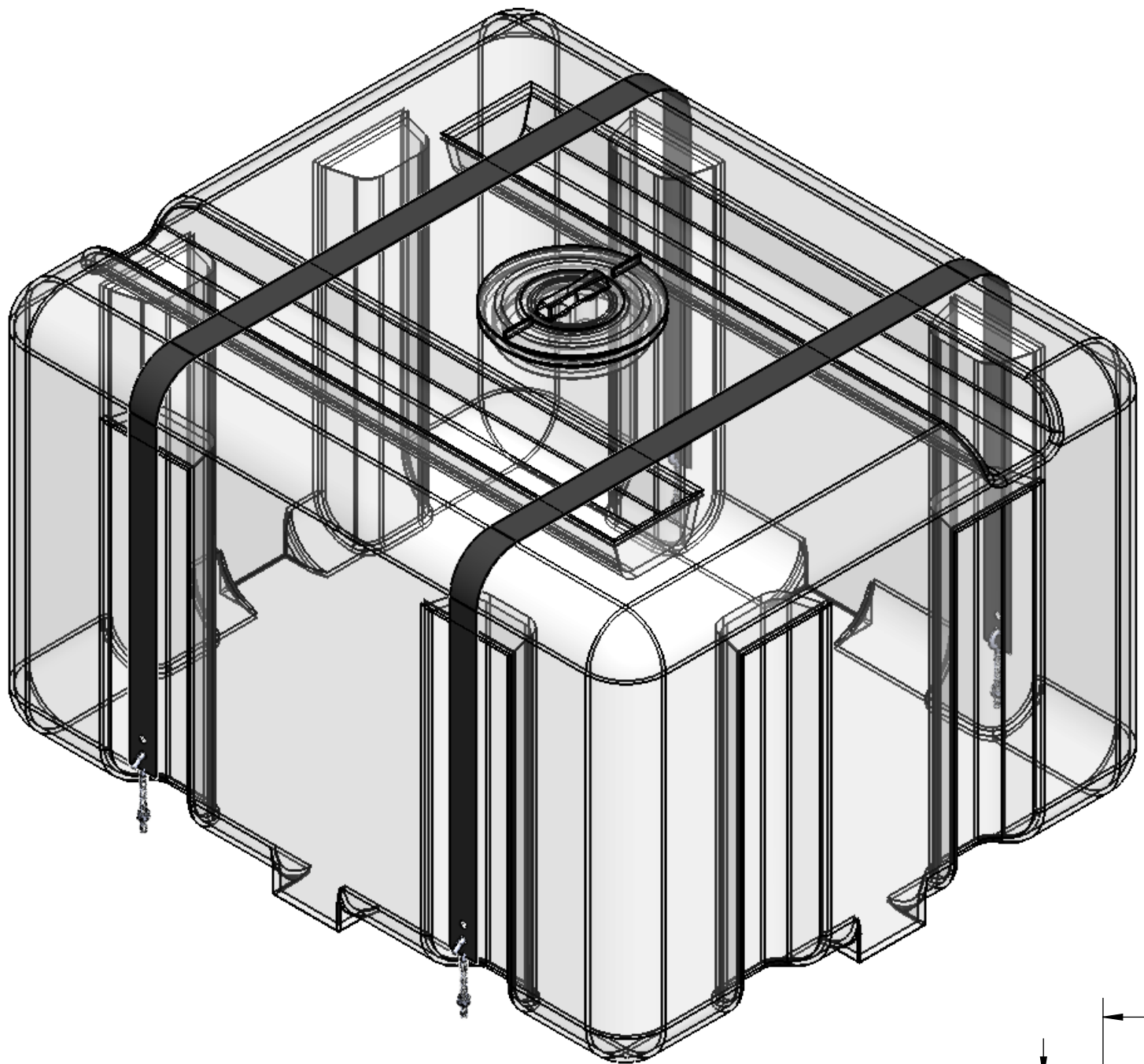

PART NUMBER	DESCRIPTION	LENGTH
50 RTBS	50 RT HOLD DOWN BAND SET	43
70 LPRTBS	70 LPRT HOLD DOWN BAND SET	52
75 RTBS	75 RT HOLD DOWN BAND SET	58
100 RTBS	100 RT HOLD DOWN BAND SET	72
110 LPRTBS	110 LPRT HOLD DOWN BAND SET	66
150 RTBS	150 RT HOLD DOWN BAND SET	82
150 RTTBS	150 RTT HOLD DOWN BAND SET	106
200 RTBS	200 RT HOLD DOWN BAND SET	92
300 RTBS	300 RT HOLD DOWN BAND SET	110
400 RTBS	400 RT HOLD DOWN BAND SET	132
500 RTBS	500 RT HOLD DOWN BAND SET	147
500 RTTBS	500 RTT HOLD DOWN BAND SET	146
NOTE: BAND SET INCLUDES (2) STEEL BANDS (4) J-HOOK BOLTS WITH WASHERS AND NUTS		

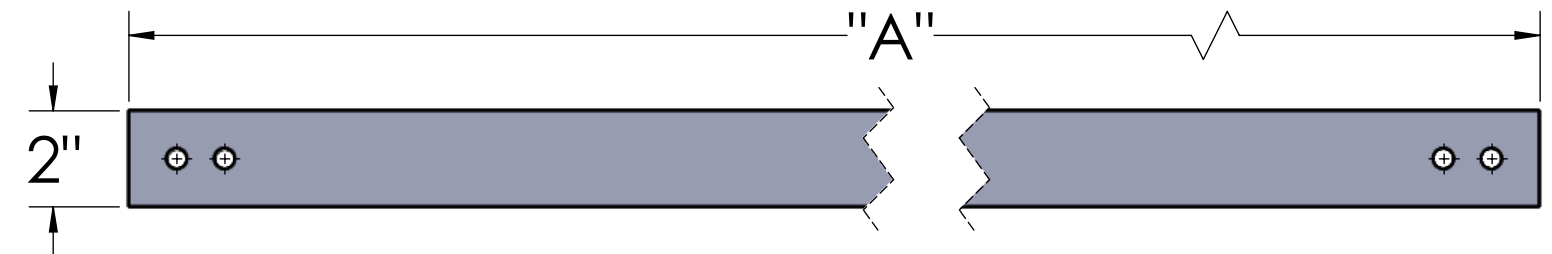

PROPRIETARY AND CONFIDENTIAL
 THE INFORMATION CONTAINED IN THIS DRAWING IS THE SOLE PROPERTY OF <INSERT COMPANY NAME HERE>. ANY REPRODUCTION IN PART OR AS A WHOLE WITHOUT THE WRITTEN PERMISSION OF <INSERT COMPANY NAME HERE> IS PROHIBITED.

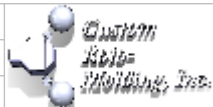
UNLESS OTHERWISE SPECIFIED:		NAME	DATE	
DIMENSIONS ARE IN INCHES TOLERANCES: FRACTIONAL ± ANGULAR: MACH ± BEND ± TWO PLACE DECIMAL ± THREE PLACE DECIMAL ±		DRAWN	EBW	
INTERPRET GEOMETRIC TOLERANCING PER:		CHECKED		TITLE:
MATERIAL		ENG APPR.		RT BAND SET
FINISH		MFG APPR.		SIZE DWG. NO. REV
NEXT ASSY	USED ON	Q.A.		B
APPLICATION	DO NOT SCALE DRAWING	COMMENTS:		SCALE: 1:16 WEIGHT: SHEET 1 OF 1